

Designer Lockers – 30000 Series

Installation Instructions

Thank you for selecting the 30000 Series Designer Lockers. We are confident that the quality and construction of the lockers will prove to be a good investment. These instructions are intended to assist you in a typical wall-anchored or back-to-back locker installation. Individual job conditions will dictate the type of fasteners and whether the lockers must be anchored to the wall, the floor, or both.

The 30000 Series Designer Lockers require minimal assembly. The basic lockers are factory assembled. It may be necessary to install the bases onto the floor, the lockers onto the bases and to each other, the optional side panels to the exposed sides of the lockers, and the lockers to a wall. See reverse side for illustration of three lockers being installed.

Hardware Supplied with Each Locker

1. (1) Metal wall strap with three holes to attach locker to wall or back-to-back. Bend the strap to tie locker to wall as shown in illustration.
2. (3) #10 x 5/8" long hex-head sheet metal screws to attach strap to top of lockers back-to-back or between locker and wall.
3. (2) #10 x 1-3/8" long hex-head machine screws to fasten lockers together side-by-side. Mating t-nuts are pre-installed in locker walls. See reverse side for illustration of three lockers being installed.
4. (2) 1-1/4" long drywall screws to attach side panel to locker.
5. (1) Number plate.

Installation Instructions

1. Bases should be set in place and leveled. The rear edge of the base should touch the wall or the other base if lockers are installed back-to-back. There are 1-wide and 3-wide bases.
2. If the back of the locker is against a wall, bend the metal strap as shown in the illustration. Set the locker on the base spaced 5/8" from the wall for ventilation air. The metal straps will be installed in Step 5 below.

Leave the metal strap flat for fastening lockers back-to-back. Allow a 1-1/4" ventilation space between the backs of lockers if lockers are back-to-back and side panels are being installed. The metal straps will be installed in Step 5 below.
3. Bolt multiple lockers together through the two unused holes and tee nuts near the door hinges.
4. Attach the finished side panels flush with the front of the locker body (not the door) allowing the excess to cover the 5/8" rear air space.
5. Once the lockers are plumb and level, attach the bent or flat metal straps to the top of the lockers and to the wall or other lockers as required.
6. Peel backing from number plate, align, and press into recess.

Illustration – 1 Locker

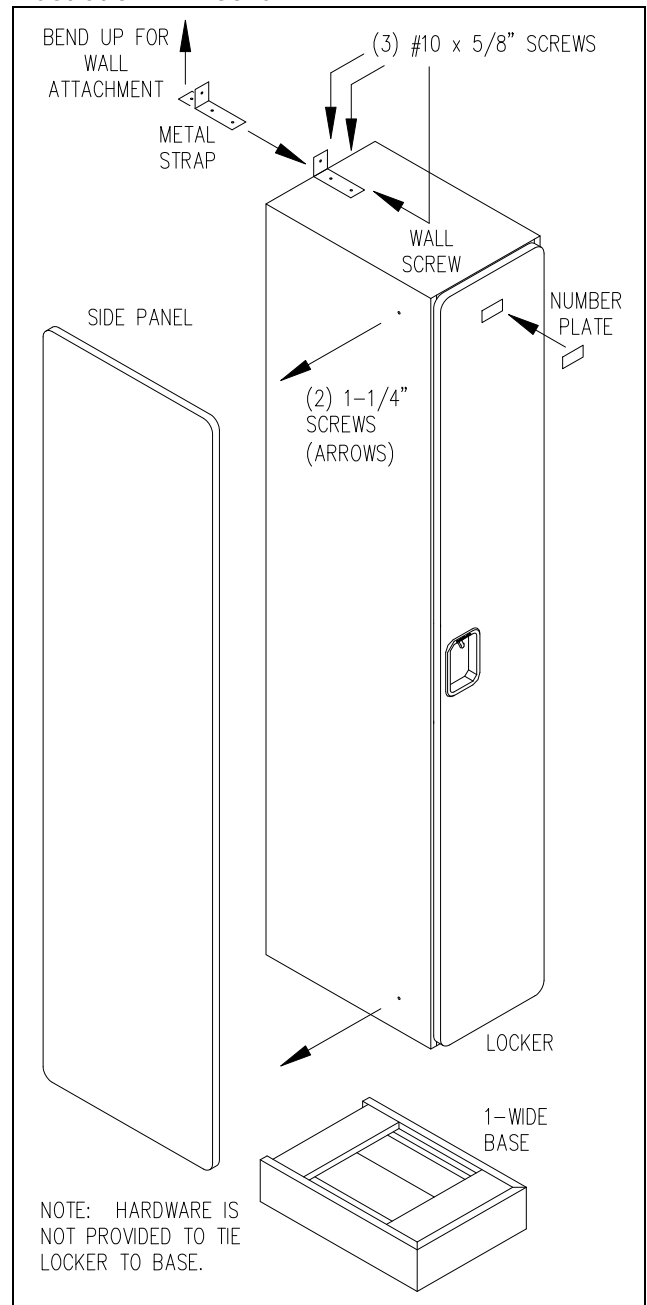
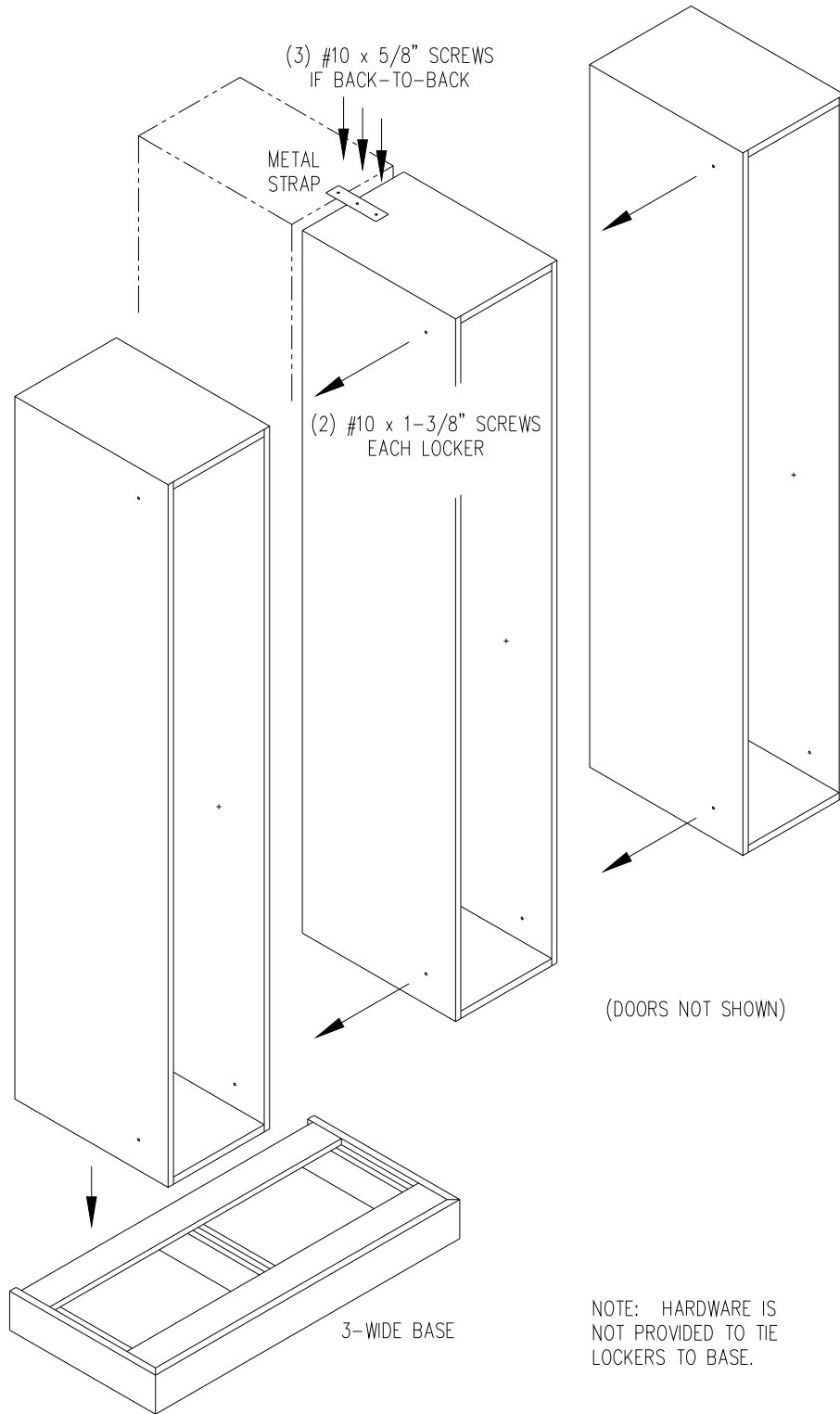

Illustration - 3 Lockers



Sloping Hood & Angled Side Panel Options For Designer Lockers - 30000 Series Installation Instructions

Thank you for selecting the 33351 or 33353 sloping hood and/or the 33334 angled side panel for the 30000 Series Designer Lockers. These instructions are intended to assist you in positioning and fastening the sloping hood and angled side panel to the locker.

Sloping Hood Installation Instructions

1 - Wide Sloping Hood

Place the sloping hood on top of locker with the front edge flush with the locker body, not the door, and the sides flush with sides of the locker. Install two (2) 1-1/4" long self-tapping dry wall screws (provided) through the ceiling of the locker compartment (from the inside) into the bottom of the sloping hood. Pre-drill two (2) pilot holes (6) inches from the front face of the locker with a 1/16" drill bit as indicated.

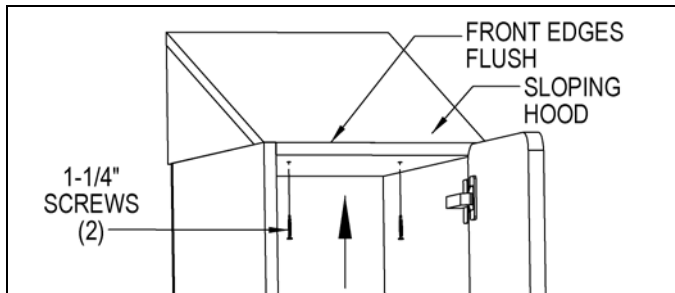

3 - Wide Sloping Hood

Place the sloping hood on top of locker with the front edge flush with the locker body, not the door, and the sides flush with sides of the locker. Install six (6) 1-1/4" long self-tapping dry wall screws (provided) through the ceiling of the locker compartment (from the inside - two (2) per compartment) into the bottom of the sloping hood. Pre-drill two (2) pilot holes per compartment six (6) inches from the front face of the locker with a 1/16" drill bit as indicated.

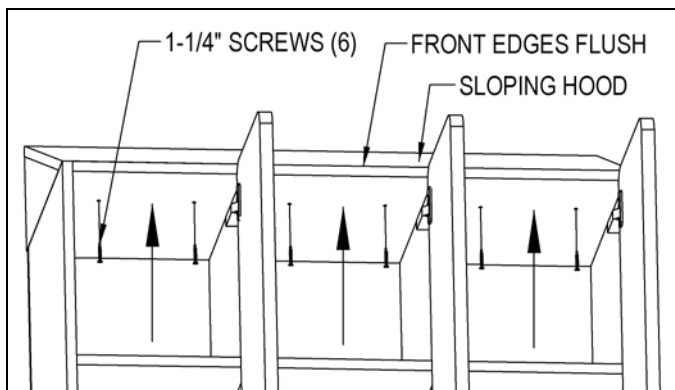

Angled Side Panel Installation Instructions

Attach the side panel flush with the front of the locker body, not the door. Install two (2) 1-1/4" long self-tapping dry wall screws (provided) in pre-drilled holes from inside the locker.

