

# Aluminum ADA Locker Bench (without back) Assembly & Installation Instructions

Thank you for selecting Salsbury Aluminum ADA locker benches. We are confident that the quality and construction of this product will provide you with years of maintenance free use.

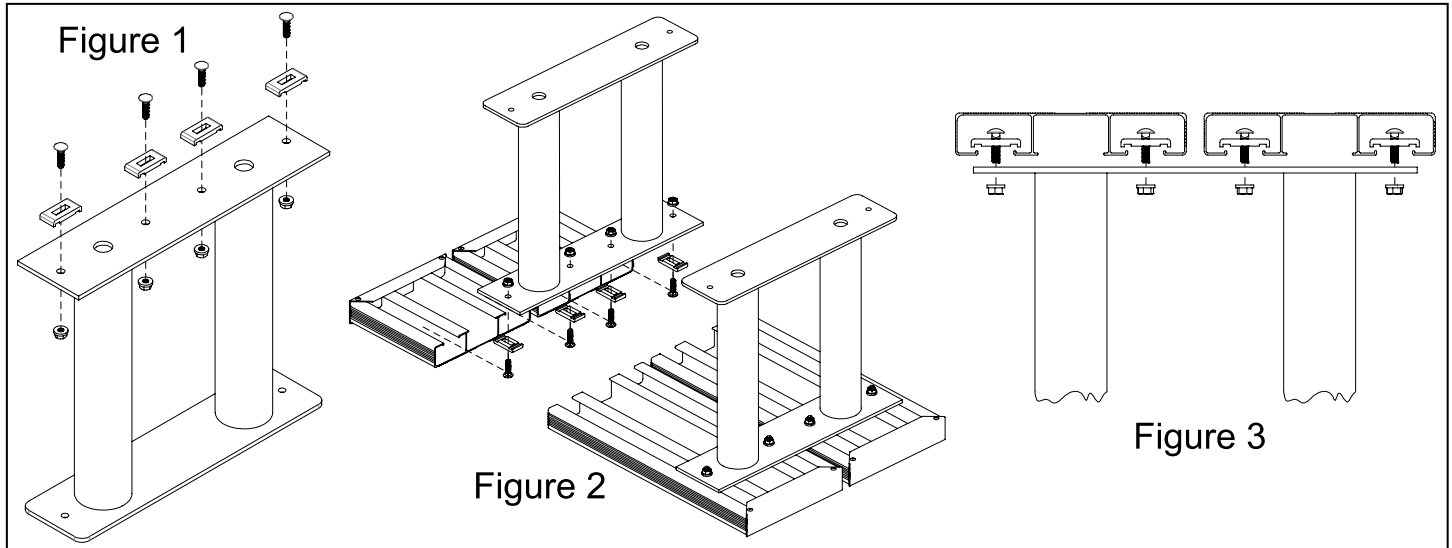

## Preliminary Notes

There are two basic steps to assembly and installation:

1. The bench pedestals must be assembled to the bench planks.
2. The bench assembly must be bolted to the floor.

***Failure to bolt the bench assembly to the floor could result in injury to persons sitting on the bench.***

Since various types of floors require different types of fasteners, floor installation hardware is not provided. The hardware provided is for fastening the bench pedestals to the bench top.

Two bench pedestals are provided for each bench, along with two bench planks that form the top. Eight (8) sets of 5/16" diameter by 1-1/4" long carriage bolts, serrated flange nuts, and straddle clamps are provided for attaching the bench pedestals to the bench planks. The pedestals should be installed 6" from each end of the planks, and the planks should be spaced 3/4" apart.

## Assembly

Install one of the carriage bolts through a straddle clamp and loosely attach it to the bench pedestal with one of the serrated flange nuts, as shown in Figure 1. The straddle clamps should be installed on the rectangular plate without rounded corners. Do this with the remaining three straddle clamps on the first bench pedestal, and repeat for the four clamps on the second bench pedestal.

Set the bench planks upside down on a flat surface. Rotate each of the straddle clamps on one bench pedestal so that they can be inserted into the bottom of the bench planks, as shown in Figure 2. Next, rotate the clamps 90 degrees so that they straddle and grip the inside lips of the bench planks when the nuts are tightened, as shown in Figure 3. Ensure that the straddle clamps are aligned with the lips. Also ensure that the square section of the carriage bolts are seated inside the square slots in the straddle clamps. Slide the bench pedestal to a position 6" from one end of the bench planks. Adjust the position of the bench planks so that they are spaced 3/4" apart, and ensure that the pedestal is centered crosswise under the bench planks. Tighten the nuts until the clamps loosely grip the lips inside the bench planks.

Repeat for the other bench pedestal. After all positioning is complete, tighten down all nuts securely.

***Complete the installation by fastening the assembled bench to the floor.***

# Aluminum ADA Locker Bench (with back)

## Assembly & Installation Instructions

Thank you for selecting Salsbury Aluminum ADA locker benches. We are confident that the quality and construction of this product will provide you with years of maintenance free use.

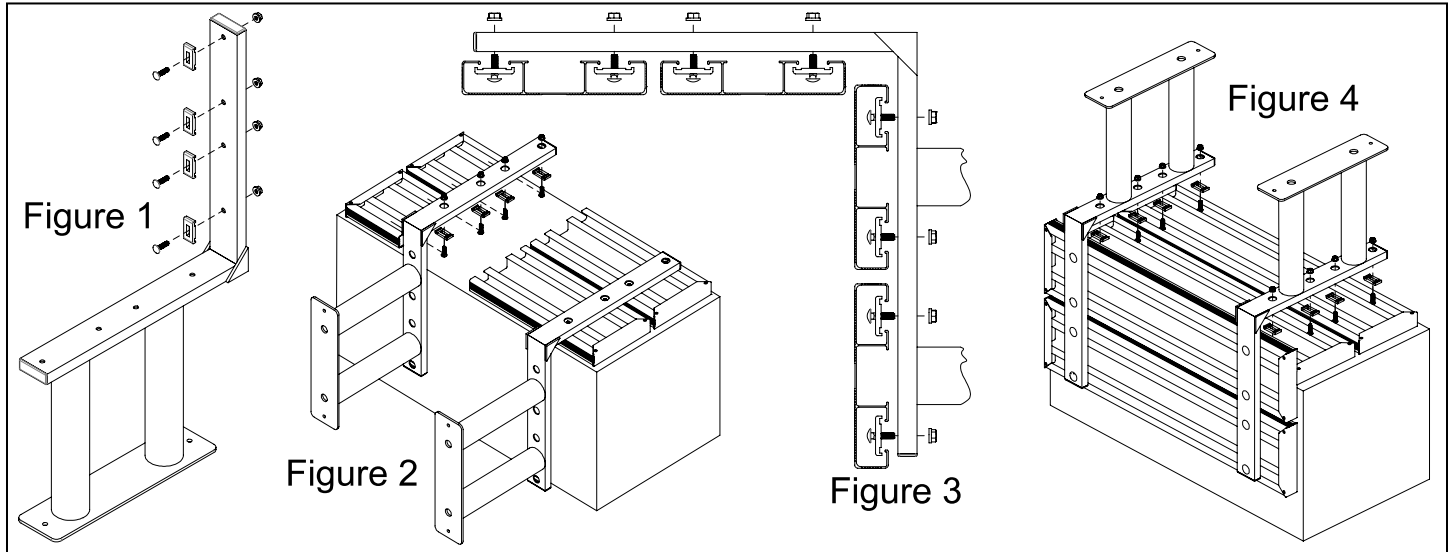

### Preliminary Notes

There are two basic steps to assembly and installation:

1. The bench pedestals must be assembled to the bench planks.
2. The bench assembly must be bolted to the floor.

***Failure to bolt the bench assembly to the floor could result in injury to persons sitting on the bench.***

Since various types of floors require different types of fasteners, floor installation hardware is not provided. The hardware provided is for fastening the bench pedestals to the bench top.

Two bench pedestals are provided for each bench. Also provided are four bench planks, two each that form the sitting surface and the back rest. Sixteen (16) sets of 5/16" diameter by 1-1/4" long carriage bolts, serrated flange nuts, and straddle clamps are provided for attaching the bench pedestals to the bench planks. The pedestals should be installed 6" from each end of the planks, and the two planks on each surface should be spaced 3/4" apart.

### Assembly

Install one of the carriage bolts through a straddle clamp and loosely attach it to the bench pedestal with one of the serrated flange nuts. The straddle clamps should be installed on the vertical member of the bench pedestal, as shown in Figure 1. Do this with the remaining three straddle clamps on the first bench pedestal, and repeat for the four clamps on the second bench pedestal.

Set two of the bench planks upside down on a flat raised work surface. Rotate each of the straddle clamps on one bench pedestal so that they can be inserted into the bottom of the bench planks, as shown in Figure 2. Next, rotate the clamps 90 degrees so that they straddle and grip the inside lips of the bench planks when the nuts are tightened, as shown in Figure 3. Ensure that the straddle clamps are aligned with the lips. Also ensure that the square section of the carriage bolts are seated inside the square slots in the straddle clamps. Slide the bench pedestal to a position 6" from one end of the bench planks. Adjust the position of the bench planks so that they are spaced 3/4" apart. Tighten the nuts until the clamps loosely grip the lips inside the bench top. Repeat for the other bench pedestal. After all positioning is complete, tighten down all nuts securely and install round hole plugs in all holes on the pedestals' vertical members.

Install the carriage bolts, straddle clamps, and nuts as before onto the horizontal members of the bench pedestals. Place the remaining two bench planks upside down on the work surface. Rotate the straddle clamps and insert them into the bottom of the bench planks, then lower the pedestals into place 6" from each end of the planks, as shown in Figure 4. Rotate the straddle clamps to grip the inside lips of the bench planks, and tighten until they grip the bench loosely. Adjust the bench planks so that they are spaced 3/4" apart, and finally tighten all nuts securely and install hole plugs in all holes on the horizontal members.

***Complete the installation by fastening the assembled bench to the floor.***